



DURO ĐAKOVIĆ

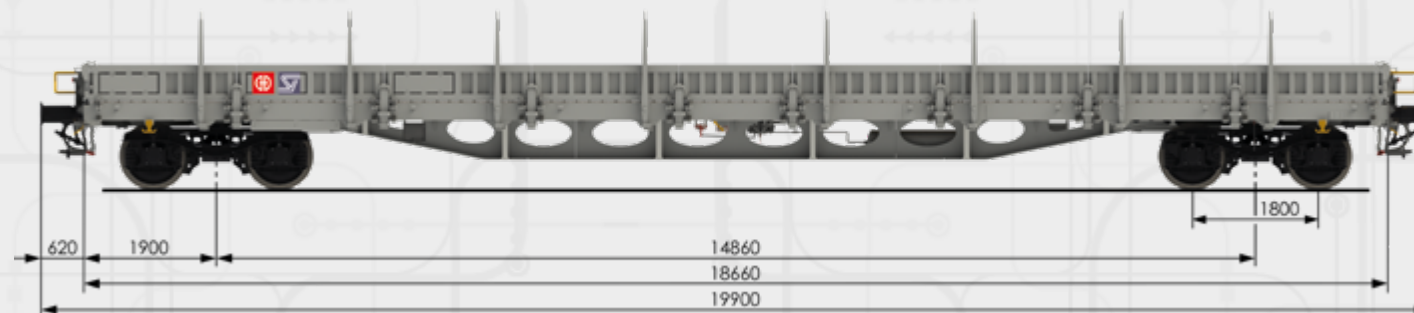


RAILWAY PROGRAM

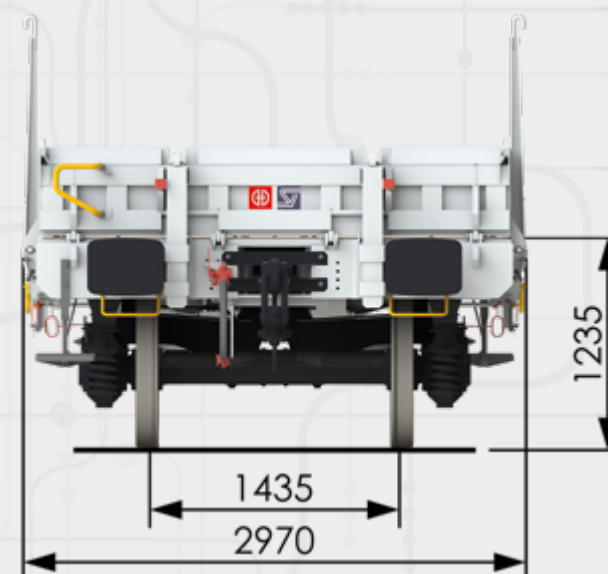
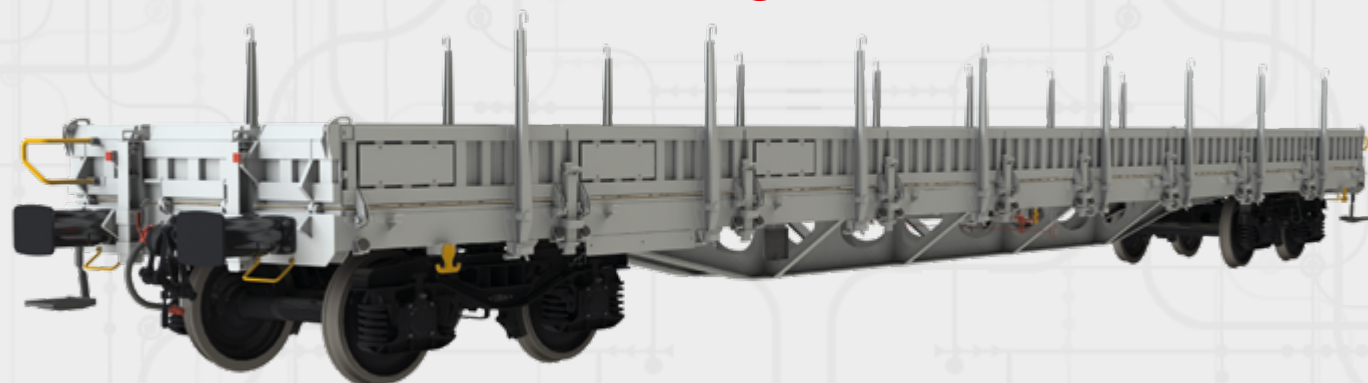


Table of content

Rens	4
Faccn(pp)s 48m ³	6
Faccn(pp)s 49m ³	8
Tagnpps 95m ³	10
Tagnpps 96m ³	12
Sgmmnss 40	14
Sgnss 60	16
Sggrss 80	18
Sggrss 90	20
Shimmns LIGHT	22
Shimmns SUPER LIGHT	24
Slmmps	26
Slmps	28
Zacns 40m ³	30
Zacns 45m ³	32
Zacns 59m ³	34
Zacns 62m ³	36
Zacns 72m ³	38
Zacns 78m ³	40
Zacns 88m ³	42
Zacns 98m ³	44
Eamnos 60m ³	46
Falns 64m ³	48
Talns64m ³	50
Uacns 75m ³	52
Uacns 68m ³	54



Rens

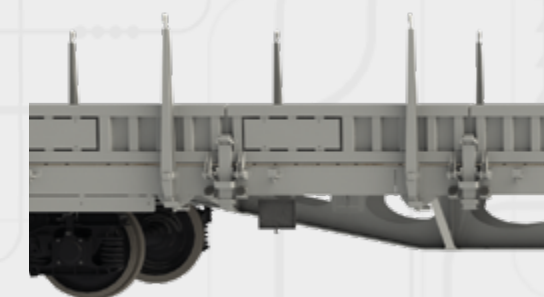


SPECIFICATIONS

Track gauge	1 435 mm
Length over buffers	19 900 mm
Tare weight	22,5 t
Max load weight	67,5 t
Max total weight	90,0 t
Bogie type	Y25 Lsd / Y25 Lsi(f)
Brake system	GP-A
Max speed (empty)	120 km/h
Max speed (loaded at 22,5 t/axle)	100 km/h
Vehicle gauge	G1, G11
Complies with standards and regulations	TSI, GCU

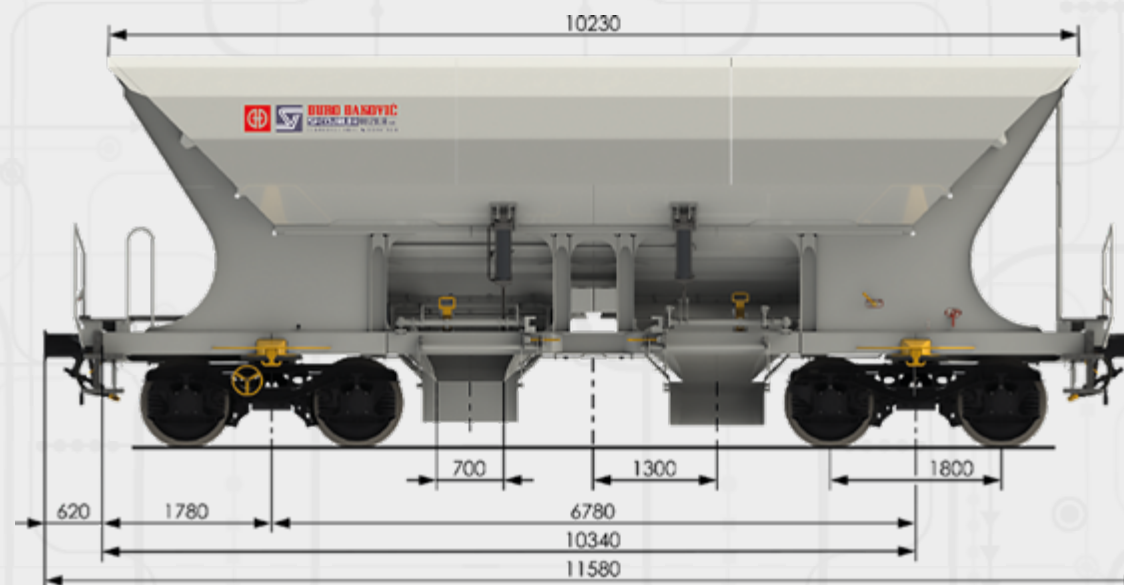
Rens is a specialized freight wagon designed primarily for the transportation of long, heavy, and bulky objects that cannot be accommodated in standard enclosed wagons. They are particularly efficient for carrying beams or columns made out of steel, timber or concrete as well as construction materials for track construction.

Rens wagons feature an open flatbed design with steel or wooden floor, and a modern stanchion system. This wagon is equipped with foldable side and front flaps. It features a standard design with reduced tare weight.





Faccn(pp)s 48 m³ SHORT



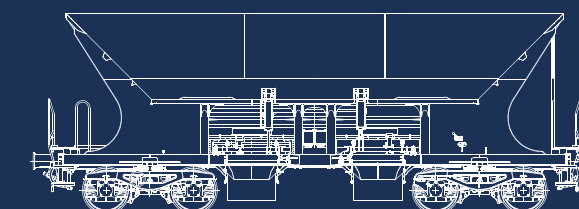
SPECIFICATIONS

Track gauge	1 435 mm
Length over buffers	11 580 mm
Tare weight	20,5 t
Max loading weight	69,5 t
Max total weight	90,0 t
Bogie type	Y25 Lsi(f)
Brake system	GP-A
Max speed (empty)	120 km/h
Max speed (loaded at 22,5 t/axle)	100 km/h
Max loading volume	48 m ³
Hand brake	from the ground
Minimum curve radius	35 m
Maximum ferry boat capability	2° 30'; R 120 m
Vehicle gauge	G1, G11
Complies with standards and regulations	TSI



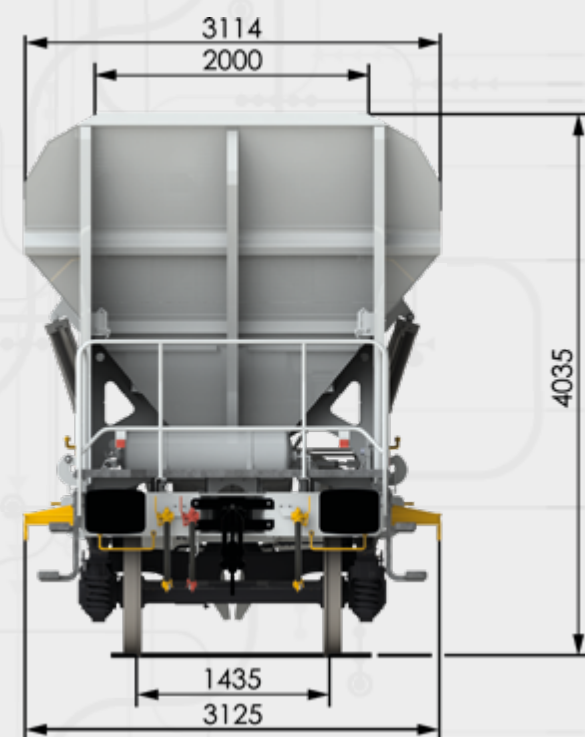
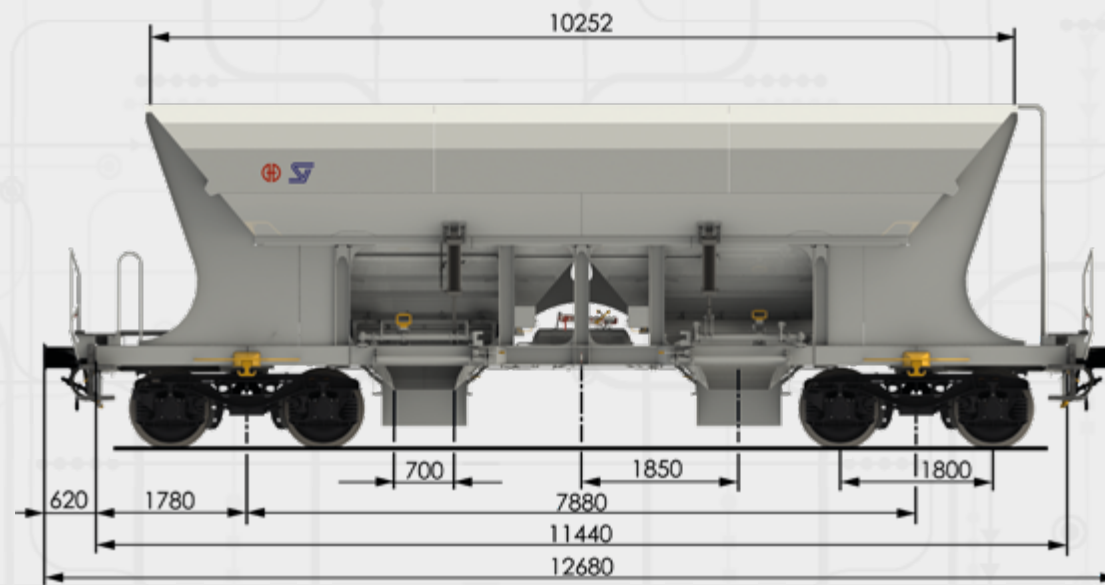
Faccn(pp)s 48 m³ is a specialized cargo wagon designed for transportation of bulk materials not requiring weather protection.

Open-top design allows easy loading of bulk materials from above. Wagon design enables efficient gravity discharging by means of two bottom hoppers. Discharging operation of the wagon is possible from both sides of the wagon and the platform. Discharging is possible from outside and between the rails. The discharge system can be installed with either pneumatic or manual operation. Both operating systems enable regulated product flow.





Faccn(pp)s 49 m³ LONG

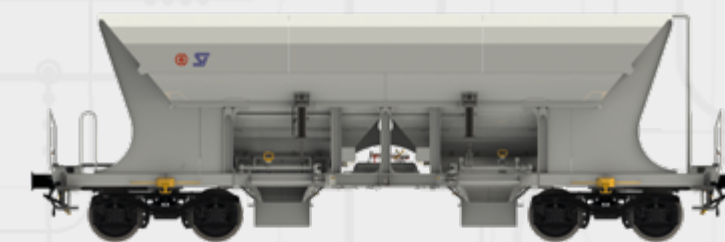
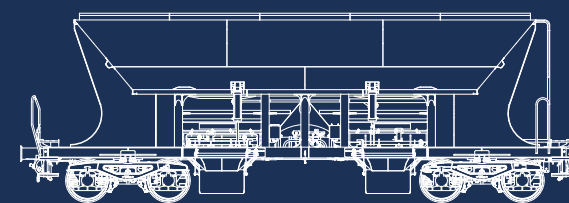


SPECIFICATIONS

Track gauge	1 435 mm
Length over buffers	12 680 mm
Tare weight	21,5 t
Max load weight	68,5 t
Max total weight	90,0 t
Bogie type	Y25 Lsi(f)
Brake system	GP-A
Max speed (empty)	120 km/h
Max speed (loaded at 22,5 t/axle)	100 km/h
Max loading volume	49 m ³
Minimum curve radius:	35 m
Maximum ferry boat capability:	2° 30'; R 120 m
Vehicle gauge	G1
Complies with standards and regulations	TSI, EN, GCU

Faccn(pp)s 49 m³ is a specialized cargo wagon designed for transportation of bulk materials not requiring weather protection.

Open-top design allows easy loading of bulk materials from above. Wagon design enables efficient gravity discharging by means of two bottom hoppers. Discharging operation of the wagon is possible from both sides of the wagon and the platform. Discharging is possible from outside and between the rails. The discharge system can be installed with either pneumatic or manual operation. Both operating systems enable regulated product flow.





Tagnpps 95 m³



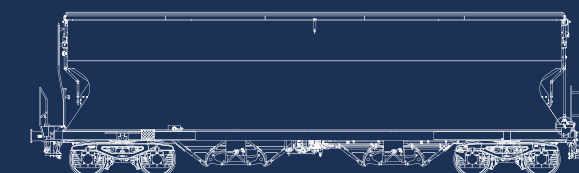
SPECIFICATIONS

Track gauge	1 435 mm
Length over buffers	14 800 mm
Tare weight	19,9 t
Boogie type	Y25 Lsi(f)
Brake system	GP-A
Max speed (empty)	120 km/h
Max speed (loaded at 22,5 t/axle)	100 km/h
Max loading volume	95 m ³
Loading opening	12 814×800 mm
Unloading opening	2 × (2×350×1000) mm
Vehicle gauge:	G1
Complies with standards and regulations	TSI, EN, GCU



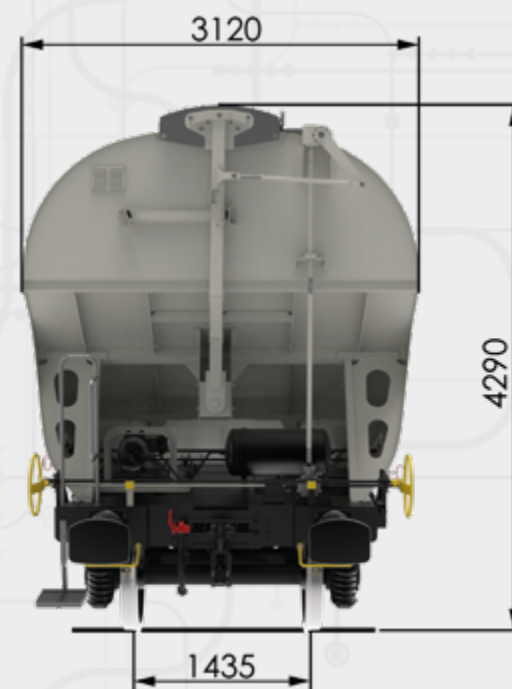
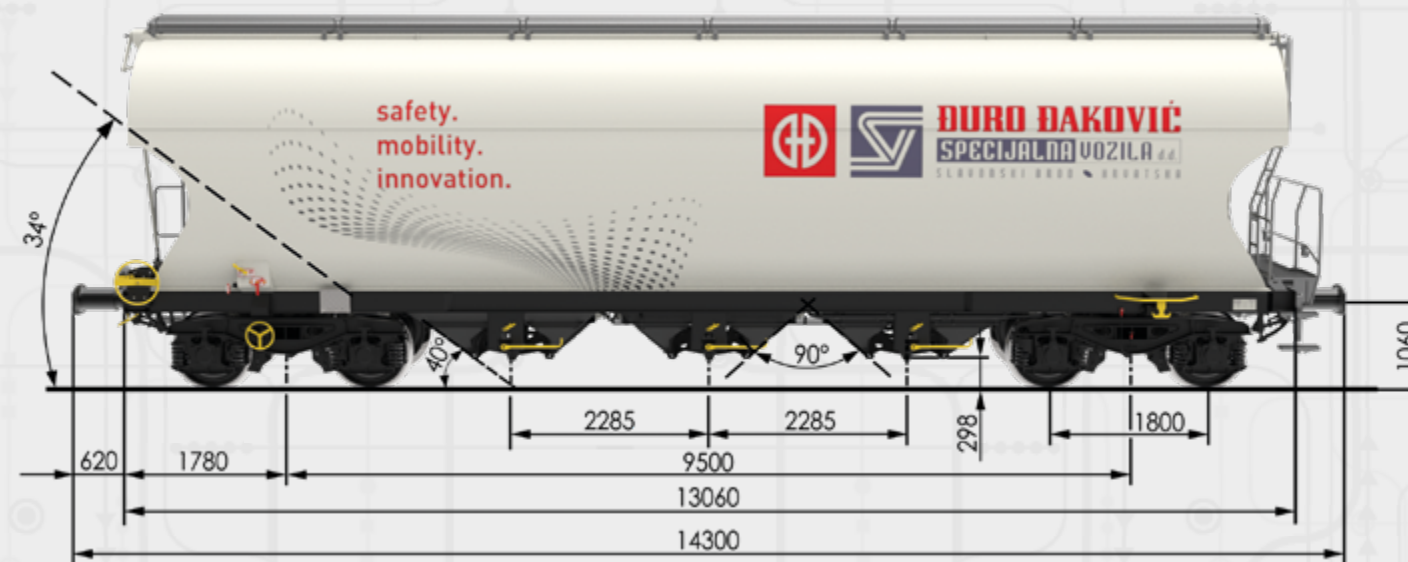
Tagnpps 95m³ is a specialized freight wagon essential for industries that require the transportation of bulk loads (grain, corn, soya, etc.), which need to be protected against weather conditions.

The wagon has a loading opening at the top that is covered with a movable roof. At the bottom there are four unloading openings that are covered by sliding flaps. The cargo is loaded at the top of the wagon. The roof is opened manually by using a handwheel, which can be operated from the ground level and is located on both sides of the wagon. The wagon is discharged by gravity between rails via two hoppers, which are individually operated from both sides.





Tagnpss 96 m³



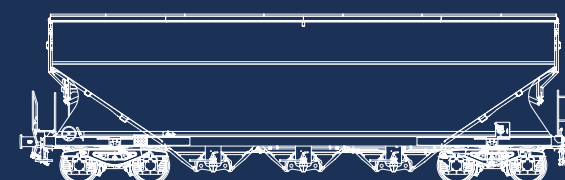
SPECIFICATIONS

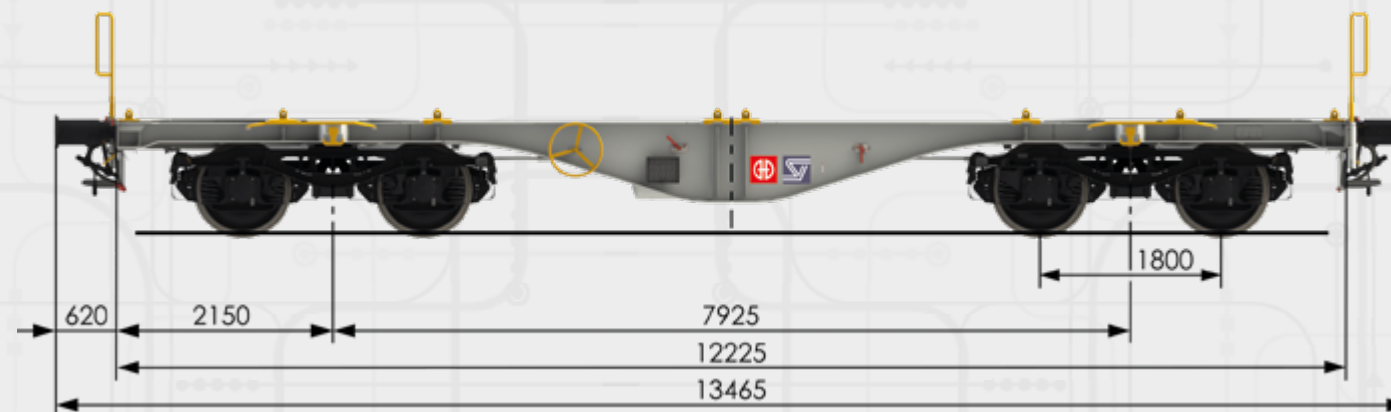
Track gauge	1 435 mm
Length over buffers	14 300 mm
Tare weight	20,1 t
Boogie type	Y25 Lsi(f)
Brake system	GP-A
Max speed (empty)	120 km/h
Max speed (loaded at 22,5 t/axle)	100 km/h
Max loading volume	96 m ³
Loading opening	12 675×800 mm
Unloading opening	3×(2×275×1 000) mm
Vehicle gauge:	G1
Complies with standards and regulations	TSI, EN, GCU

Tagnpss 96m³ is a specialized freight wagon essential for industries that require the transportation of bulk loads (grain, corn, soya, etc.), which need to be protected against weather conditions.

The wagon has a loading opening at the top that is covered with a movable roof. At the bottom there are six unloading openings that are covered by sliding flaps. The cargo is loaded at the top of the wagon. The roof is opened manually by using a handwheel, which can be operated from the ground level and is located on both sides of the wagon. The wagon is discharged by gravity between rails via two hoppers, which are individually operated from both sides.

This wagon features a shorter design, increased volume and stainless-steel roof without rubber sealing. Wagon is equipped with redesigned roof mechanisms that ensures easier roof operation.

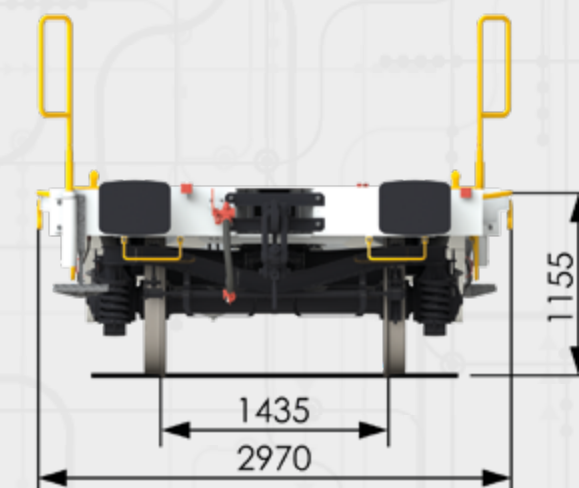




Sgmmnss 40'

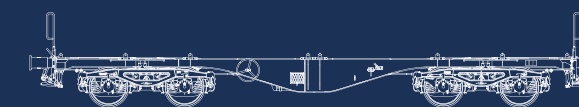
SPECIFICATIONS

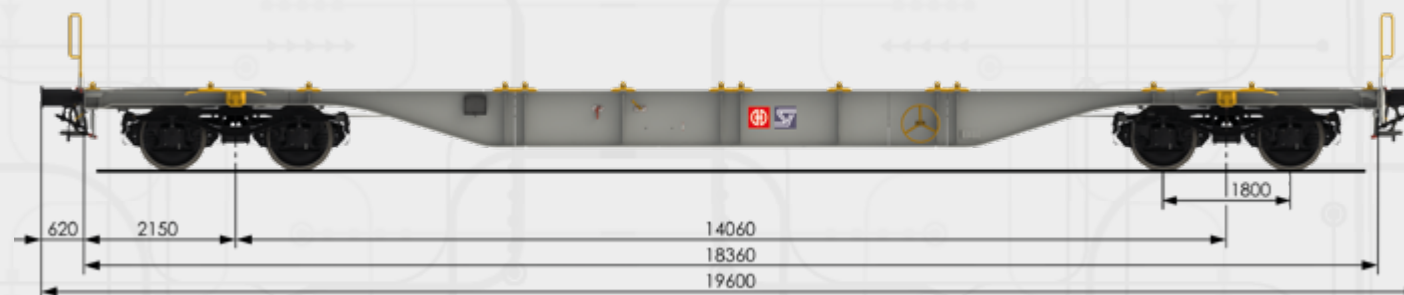
Track gauge	1 435 mm
Length over buffers	13 465 mm
Tare weight	16,0 t
Max loading weight	74,0 t
Max total weight	90,0 t
Bogie type	Y25 Ls1-K
Brake system	GP-A
Max speed (loaded at 20 t/axle)	120 km/h
Max speed (loaded at 22,5 t/axle)	100 km/h
Minimum curve radius	75 m
Maximum ferry boat capability	1° 30'; R 120 m
Vehicle gauge	G1, G11
Complies with standards and regulations	TSI



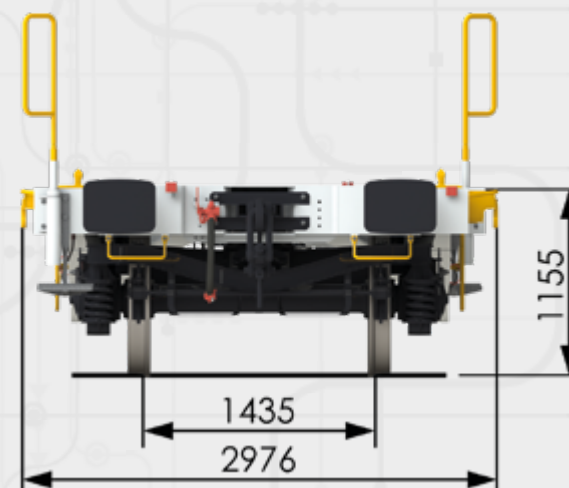
Sgmmnss 40' is a specialized freight wagon designed for the transportation of containers of various lengths (20', 30' and 40') and swap bodies.

Flatbed design makes this wagon ideal for accessing, loading and carrying large, heavy and oversized cargo. Its fastening mechanism consists of 4 fixed corner and 12 adjustable spigots, it allows for quick and safe transport, while reducing downtime and increasing efficiency.





Sgnss 60'



SPECIFICATIONS

Track gauge	1 435 mm
Length over buffers	19 600 mm
Tare weight	19,0 t
Max loading weight	71,0 t
Max total weight	90,0 t
Bogie type	Y25 Ls1-K
Brake type	GP-A
Max. speed (loaded at 20 t/axle)	120 km/h
Max. speed (loaded at 22,5 t/axle)	100 km/h
Minimum curve radius	75 m
Maximum ferry boat capability	1° 30'; R 120 m
Vehicle gauge	G1
Complies with standards and regulations	TSI

Sgnss 60' is a specialized freight wagon designed for the transportation of containers of various lengths (20', 30' and 40') and swap bodies.

The flatbed design makes them ideal for accessing, loading and carrying large, heavy and oversized cargo. Its fastening mechanism consists of 28 spigots and allows for quick and safe transport, while reducing downtime and increasing efficiency.



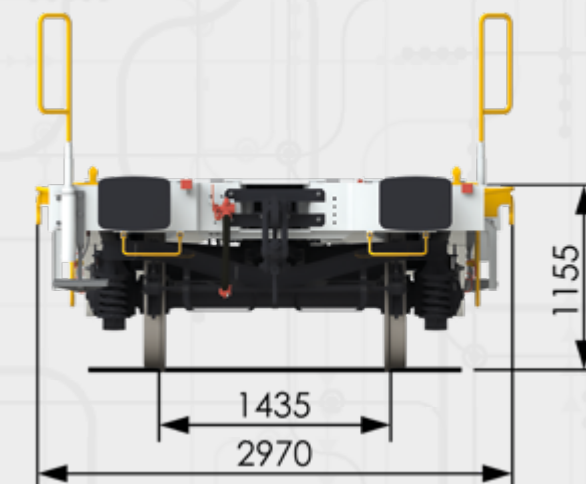


Sggrs 80'



SPECIFICATIONS

Track gauge	1 435 mm
Length over buffers	26 390 mm
Tare weight	26,5 t
Max loading weight	108,5 t
Max total weight	135,0 t
Bogie type	Y25 Ls(s)(d)1-K
Brake type	GP-A
Max speed (loaded at 20 t/axle)	120 km/h
Max speed (loaded at 22,5 t/axle)	100 km/h
Minimum curve radius	75 m
Maximum ferry boat capability	1° 30'; R 120 m
Vehicle gauge	G1, G11
Complies with standards and regulations	TSI



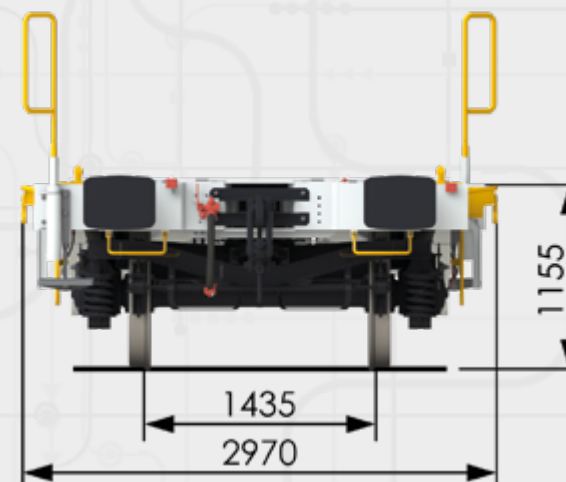
Sggrs 80' is a specialized freight wagon designed for the transportation of containers of various lengths (20', 30' and 40') and swap bodies.

Flatbed design allows easy access and loading of ISO containers and swap bodies. The unit consists of 2 bodies with a shared bogie, providing greater stability and flexibility. Robust construction and securing mechanisms ensure a high payload capacity of 108,5 t, while reducing handling time and operational delays.





Sggmrss 90'



SPECIFICATIONS

Track gauge	1 435 mm
Length over buffers	29 590 mm
Tare weight	27,9 t
Max loading weight	107,1 t
Max total weight	135,0 t
Bogie type	Y25 Ls(s)(d)1-K
Brake system	GP-A
Max speed (loaded at 20 t/axle)	120 km/h
Max speed (loaded at 22,5 t/axle)	100 km/h
Minimum curve radius	75 m
Maximum ferry boat capability	1° 30'; R 120 m
Vehicle gauge	G1, G11
Complies with standards and regulations	TSI

Sggmrss 90' is a specialized freight wagon designed for the transportation of containers of various lengths (20', 30', 40' and 45') and swap bodies.

Flatbed design allows easy access and loading of ISO containers and swap bodies. The unit consists of 2 bodies with a shared bogie, providing greater stability and flexibility. Robust construction and securing mechanisms ensure a high payload capacity of 107,1 t while reducing handling time and operational delays.





Shimmns LIGHT



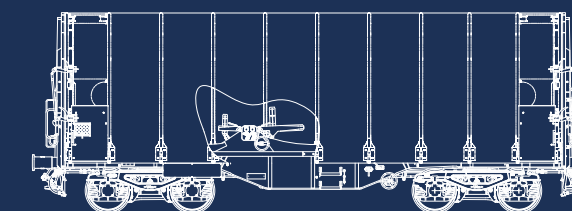
SPECIFICATIONS

Track gauge	1 435 mm
Length over buffers	12 040 mm
Tare weight	19,8 t
Bogie type	Y25 Lsi
Brake system	GP-A
Max speed (empty)	120 km/h
Max speed (loaded at 22,5 t/axle)	100 km/h
Width of cradle	2 400 mm
Coil width	max 2 052 / min 352.
Max loading temperature	max 80°C
Vehicle gauge:	G1
Complies with standards and regulations	TSI, GCU



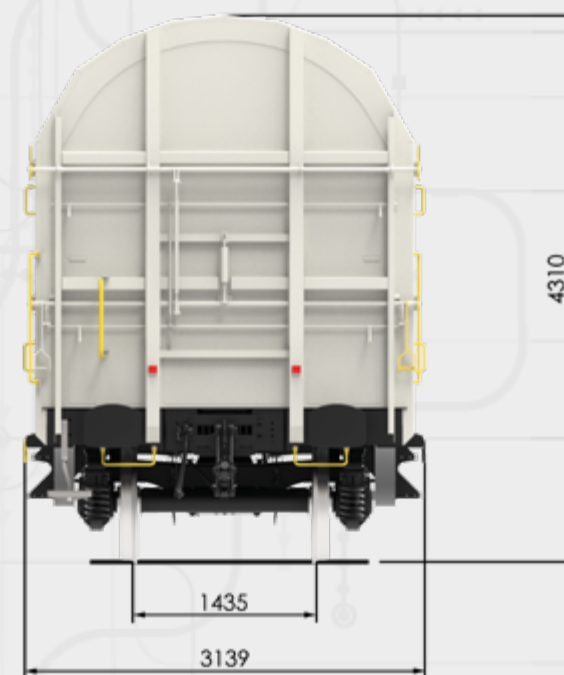
Shimmns light is a specialized railway freight wagon designed primarily for transportation of cold steel coils, by placing them in their cradles. Shimmns wagons are a key link in the logistics chain for industries that use large volumes of steel coils, providing a safe, reliable and efficient means of transportation.

The Shimmns wagon has 5 cradles for steel coils. The coils are secured by aluminum coil securing arms and protected against environmental conditions by a tarpaulin, which can be rolled at both wagon ends. A fully opened tarpaulin cover allows the efficient loading and unloading process. Industrial cranes and forklifts can access the coils from the top and from both sides.





Shimmns SUPERLIGHT

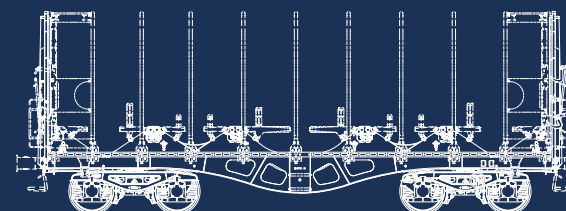


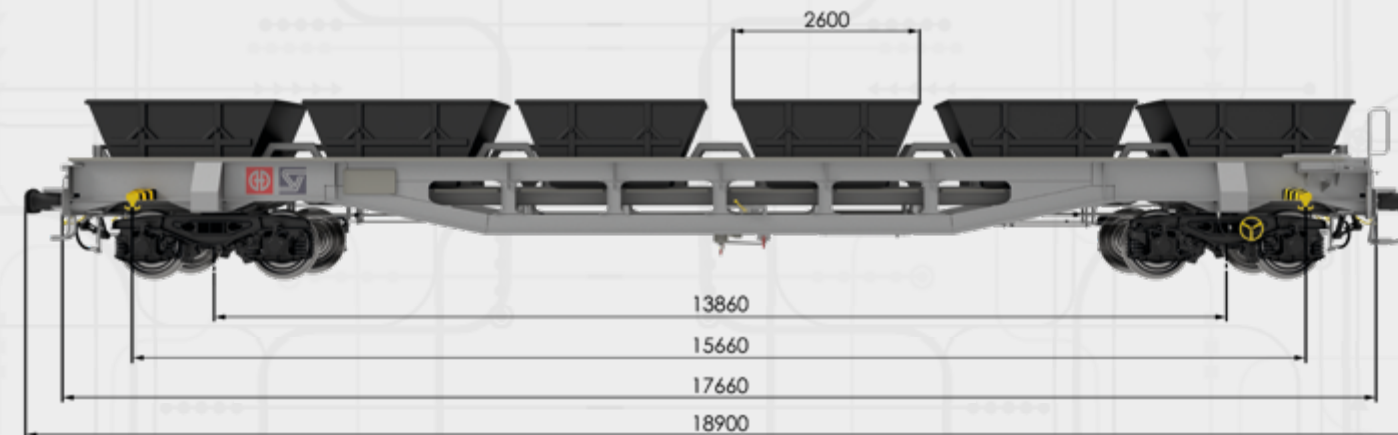
SPECIFICATIONS

Track gauge	1 435 mm
Length over buffers	12 040 mm
Tare weight	18,6 t
Bogie type	Y25 Lsi
Brake system	GP-A
Max speed (empty)	120 km/h
Max speed (loaded at 22,5 t/axle)	100 km/h
Width of cradle	2 475 mm
Coil width	max 2 140 mm / min 335 mm
Max loading temperature	max 80°C
Vehicle gauge:	G1
Complies with standards and regulations	TSI, GCU

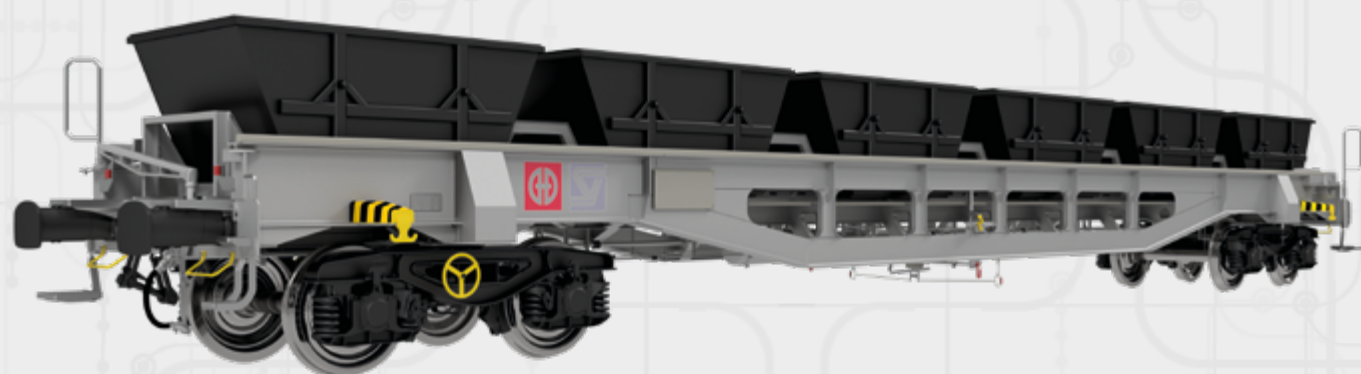
Shimmns superlight is a freight wagon primarily used for transporting cold steel coils, by placing them in their cradles. It features a redesigned welded steel structure, optimized for minimal tare weight of the wagon. Shimmns wagons are a key link in the logistics chain for industries that use large volumes of steel coils, providing a safe, reliable and efficient means of transportation.

The Shimmns wagon has 5 cradles for steel coils. The coils are secured by securing arms and protected against environmental conditions by a tarpaulin, which can be rolled at both wagon ends. A fully opened tarpaulin cover allows the efficient loading and unloading process. Industrial cranes and forklifts can access the coils from the top and from both sides.



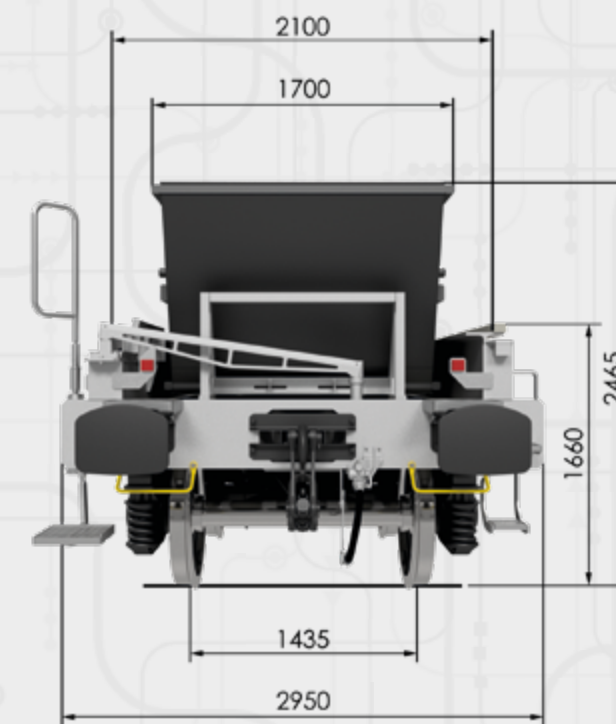


Slmmps



SPECIFICATIONS

Track gauge	1 435 mm
Length over buffers	18 900 mm
Tare weight (with containers)	26,0 t
Container max total weight (6 pcs)	8,0 t
Max total weight	90,0 t
Bogie type	Y25 Lsi(f)
Brake system	GP-A
Max speed (empty)	120 km/h
Max speed (loaded at 22,5 t/axle)	100 km/h
Min. curve radius	75 m
Complies with standards and regulations	TSI, GCU



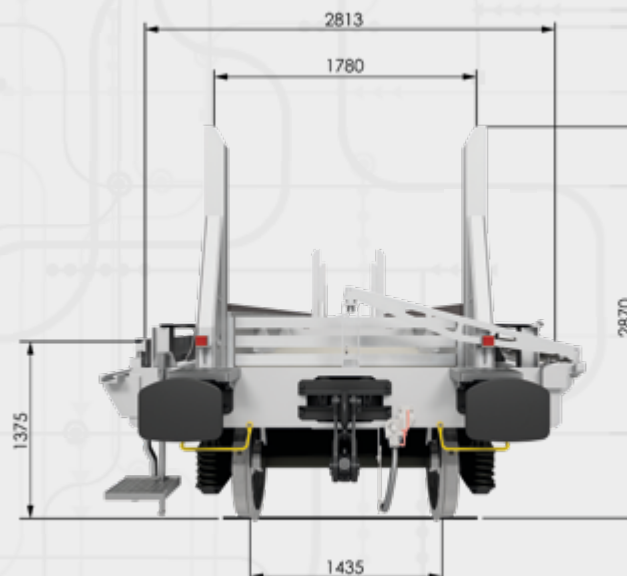
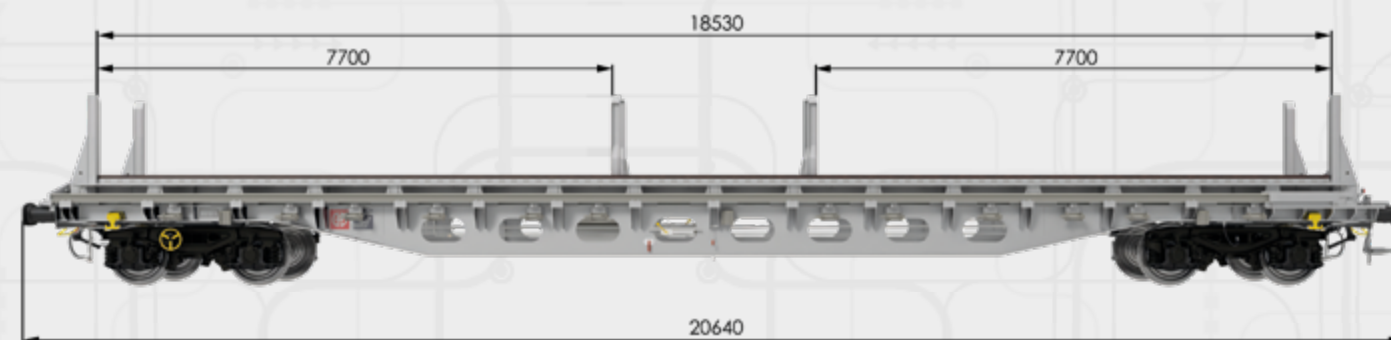
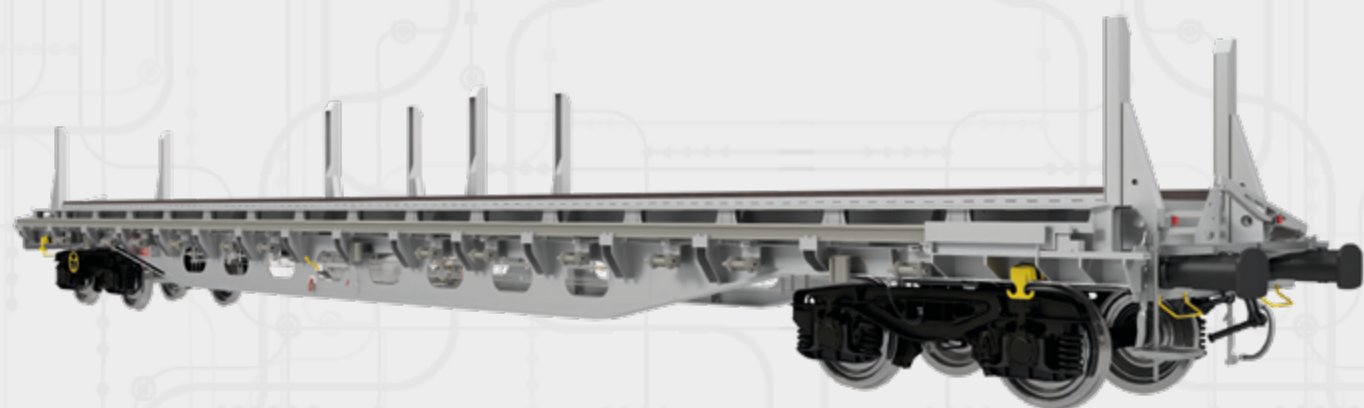
Slmmps is a specialized type of cargo wagon designed for railroad infrastructure newbuild projects and maintenance operations. It features a flatbed design with removable containers equipped with standardized fittings to secure them.

The containers are placed and removed from the wagon by a specific gantry crane. For this purpose, the wagon is fitted with longitudinal rails that enable the gantry crane to move along the wagons in a composition. The containers are placed in fixed cradles, designed to accommodate 6 containers per wagon. Containers are part of the wagon and included in the tare weight. Each individual container has a maximum loaded weight of 8 t. The wagon bed frame is designed to accept containers with a total weight of 10,6 t per container.





Slnps



SPECIFICATIONS

Track gauge	1 435 mm
Length over buffers	20 640 mm
Loading space length	18 530 mm
Tare weight	26,0 t
Max Total weight	90,0 t
Bogie type	Y25 Lsi(f)
Brake system	GP-A
Max speed (empty)	120 km/h
Max speed (loaded at 22,5 t/axle)	100 km/h
Min. curve radius	60 m
Complies with standards and regulations	TSI, EN, UIC, GCU

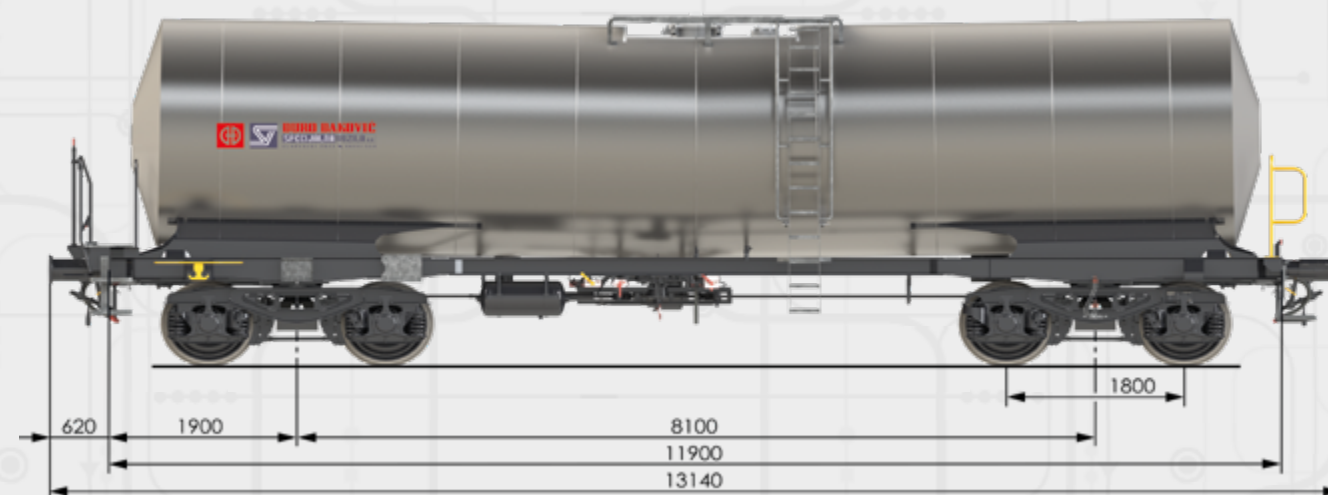
Slnps is a specialized cargo wagon designed for transporting different types of railway sleepers during railroad maintenance. The sleepers are loaded and unloaded by a specific gantry crane.

For this purpose, the wagon is fitted with longitudinal rails and connection pieces that ensure connection of the rails between the wagons. That enables the gantry crane to move along the wagons in a composition. To additionally fasten the sleepers, the wagon is equipped with belt tension system. The wagon can accept additional rail holding equipment on the wagon.





Zacens 40 m³



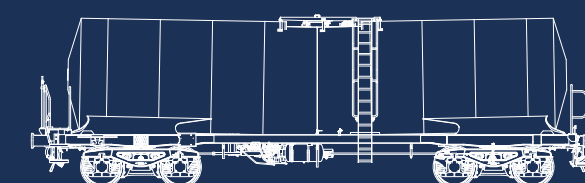
SPECIFICATIONS

Track gauge	1 435 mm
Length over buffers	13 140 mm
Tare weight	21,5 t
Max load weight	68,5 t
Max total weight	90,0 t
Bogie type	Y25 Lsd / Y25 Lsi(f)
Brake system	GP / GP-A
Maximum speed (empty)	120 km/h
Maximum speed (loaded at 22,5 t/axle)	100 km/h
Load volume	40 m ³
Tank code	L4DH / L10DH
Tank material	P355GH
Tank calculation pressure	4 / 10 bar
Tank test pressure	4 bar
Operating pressure	3 bar
Tank calculation temperature	-20 / +190 °C
Vehicle gauge	G1
Meets standards and regulations	TSI, GCU



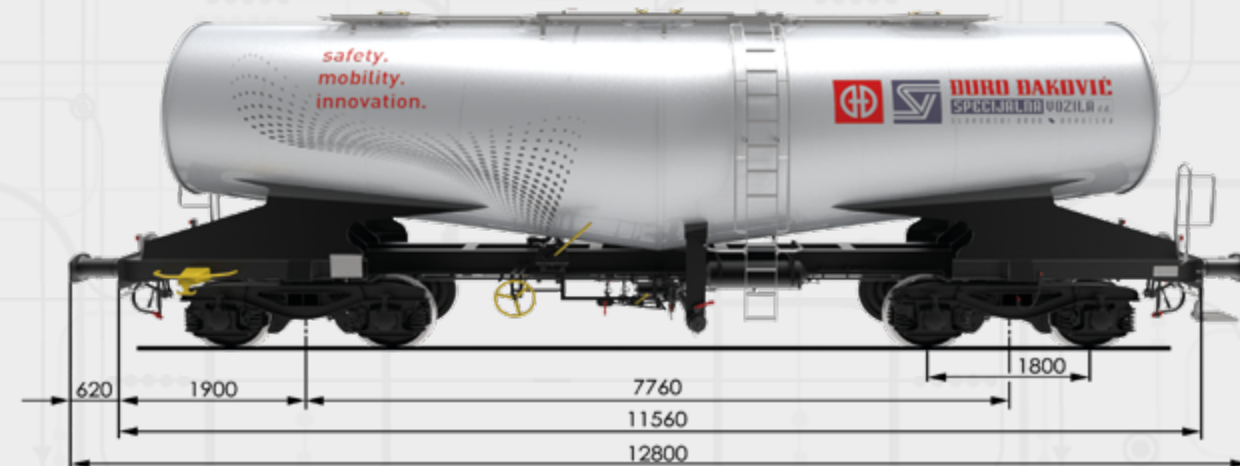
Zacens 40 m³ is a specialized type of cargo wagon designed for transporting temperature-sensitive liquids, such as certain chemicals, oils, and petroleum products. The presence of a heating system makes them particularly suitable for substances that solidify or become highly viscous at lower temperatures.

The main feature of Zacens 40 m³ wagon is a cylindrical tank with a capacity of 40 m³. The tank is constructed from a material with high resistance to chemical corrosion. It is strong enough to withstand internal pressures and the physical demands of transport. The heating capability allows these wagons to transport substances that need to be kept at a certain temperature. As part of its safety features, the wagon includes a reinforced tank, a pressure relief valve and emergency shutoff valves.





Zacns 45 m³

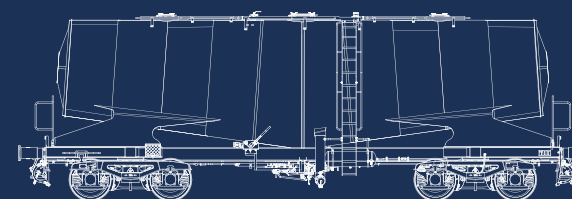


SPECIFICATIONS

Track gauge	1 435 mm
Length over buffers	12 800 mm
Tare weight	19,5 t
Max total weight	90,0 t
Bogie type	Y25 Lsd
Brake system	GP-A
Max speed (empty)	120 km/h
Max speed (loaded at 22,5 t/axle)	100 km/h
Tank volume	45 m ³
Tank material	X2CrNi18-9
Loading hole diameter	500 mm (DN 500)
Cleaning hole diameter	2 x 300 mm (DN 300)
Discharge pipe diameter	100 mm (DN 100)
Operating pressure	2 bar
Min. curve radius	35 m
Vehicle gauge	G1
Complies with standards and regulations	TSI, EN, GCU

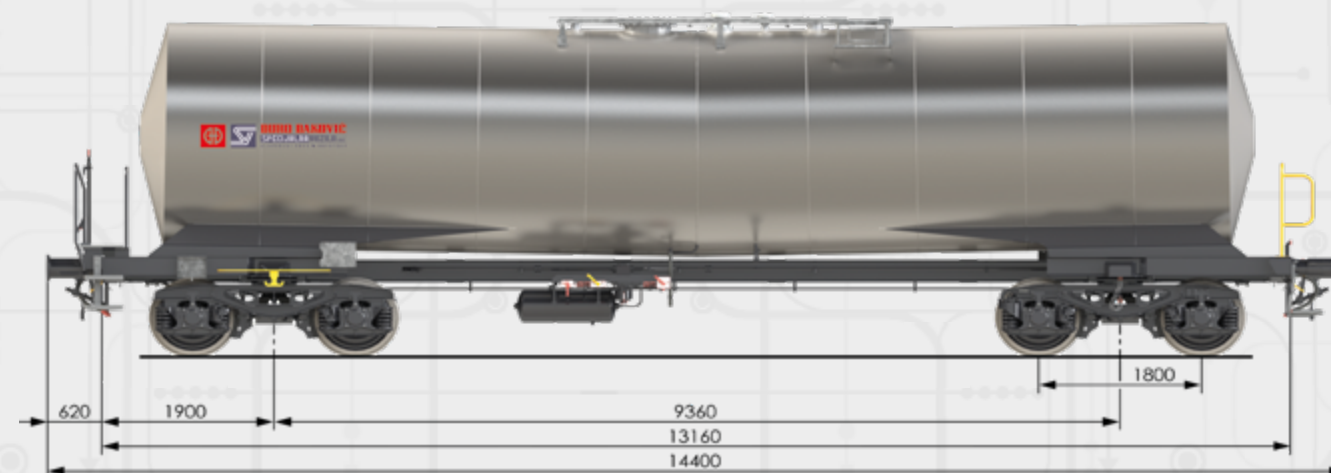
Zacns 45 m³ is a specialized cargo wagon designed for transporting liquid substances, it is especially effective for carrying CaCO₃ slurry.

Zacns 45 m³ has a cylindrical tank design, which is optimized for carrying up to 45 m³. The tank is constructed from a specialized cold rolled stainless steel X2CrNi18-9 to ensure durability and resistance to corrosion in working pressure conditions of 2 bar. The outer insulation of the tank consists of mineral wool with a top coating made of 0,8 mm thick prepainted anodized steel. Cargo is loaded from above the tank, through one manually operated DN 500 opening. Unloading can be performed through discharge pipes located at the bottom of the wagon, gravity-assisted, by compressed air or auxiliary pumps. The tank is also equipped with one overpressure and vacuum safety valve and two cleaning openings (DN 300).





Zacens 59 m³



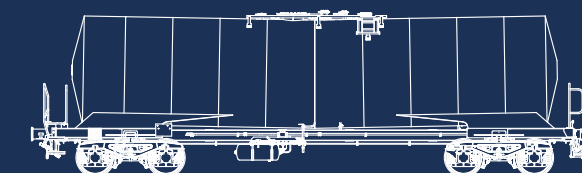
SPECIFICATIONS

Track gauge	1 435 mm
Length over buffers	14 400 mm
Tare weight	22,2 t
Max load weight	67,8 t
Max total weight	90,0 t
Bogie type	Y25 Lsd / Y25 Lsi(f)
Brake system	GP-A
Maximum speed (empty)	120 km/h
Maximum speed (loaded at 22,5 t/axle)	100 km/h
Load volume	59 m ³
Tank code	L4DH
Tank material	P355N
Tank calculation pressure	4 bar
Tank test pressure	4 bar
Tank operating pressure	3 bar
Tank calculation temperature	-20 / +190 °C
Vehicle gauge	G1
Meets standards and regulations	TSI, GCU



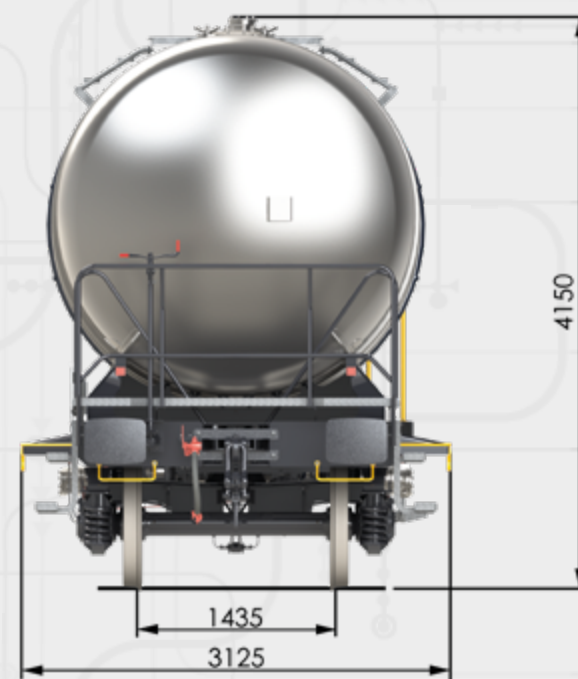
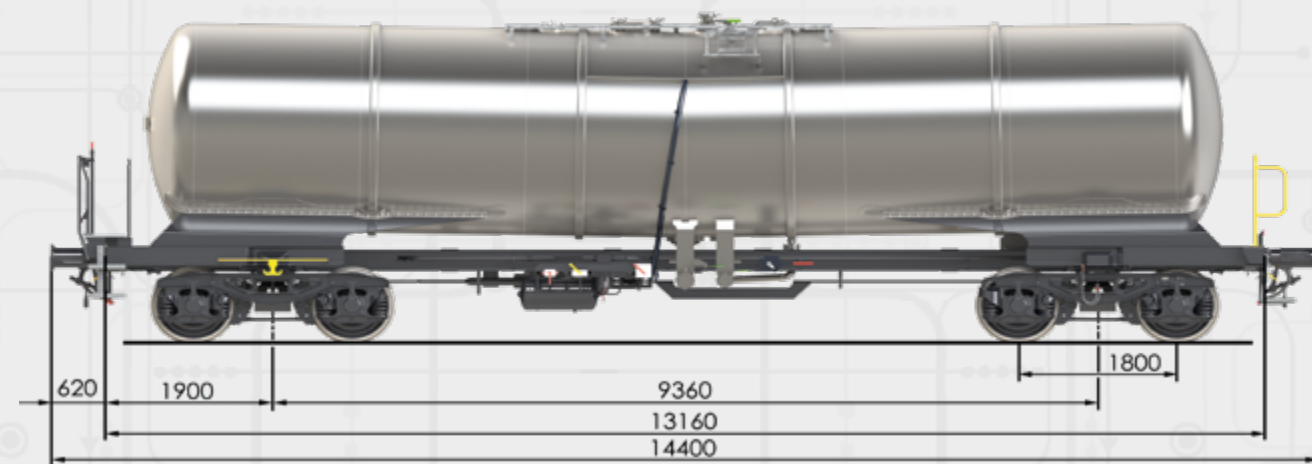
Zacens 59 m³ is a specialized type of cargo wagon designed for transporting temperature-sensitive liquids, such as certain chemicals, oils, and petroleum products. The presence of a heating system makes them particularly suitable for substances that solidify or become highly viscous at lower temperatures.

The main feature of Zacens 59 m³ wagon is a cylindrical tank with a capacity of 59 m³. The tank is constructed from a material with high resistance to chemical corrosion. It is strong enough to withstand internal pressures and the physical demands of transport. The heating capability allows these wagons to transport substances that need to be kept at a certain temperature. As part of its safety features, the wagon includes a reinforced tank, a pressure relief valve and emergency shutoff valves.





Zacns 62 m³

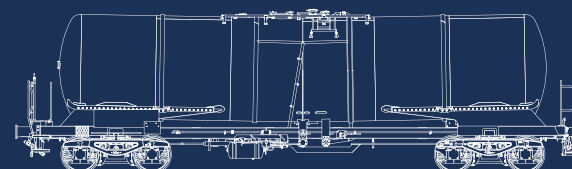


SPECIFICATIONS

Track gauge	1 435 mm
Length over buffers	14 400 mm
Tare weight	21,0 t
Maximum load weight	69,0 t
Maximum total weight	90,0 t
Bogie type	Y25 Lsd / Y25 Lsi(f)
Brake system	GP / GP-A
Max speed (empty)	120 km/h
Max speed (loaded at 22,5 t/axle)	100 km/h
Tank load volume	62 m ³
Tank code	L4DH / L4BH
Tank material	P355N
Calculation pressure	10 bar
Test pressure	4 bar
Operating pressure	3 bar
Loading hole diameter	500 mm (DN 500)
Discharge pipe diameter	125 mm (DN 125)
Min. curve radius	35 m
Vehicle gauge	G1
Complies with standards and regulations	TSI, EN, GCU

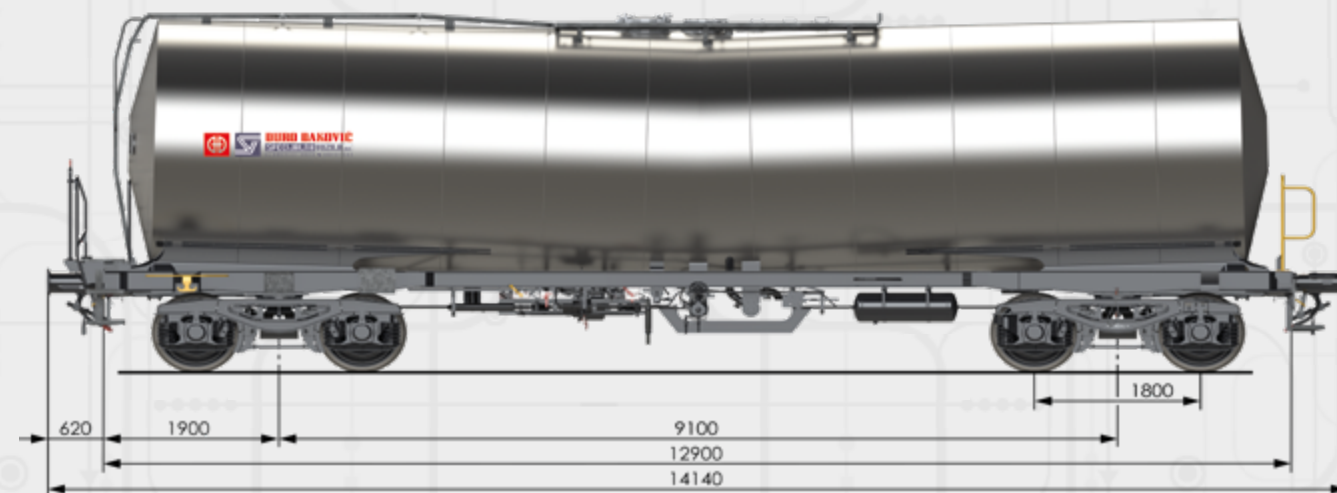
Zacns 62 m³ is a specialized cargo wagon designed for the transportation of liquid goods, mainly hazardous substances, such as almost all OF chemicals.

The main feature of Zacns 62 m³ wagon is a cylindrical tank with a capacity of 62 m³. The tank is constructed from carbon steel P355GH supplemented with internal coating to maximize resistance to chemical corrosion. Second option is the tank from stainless steel 1.4571. The wagon design meets the requirements of RID, TSI, EN, standards and has TEN GE marking for traffic operation.





Zacens 72 m³



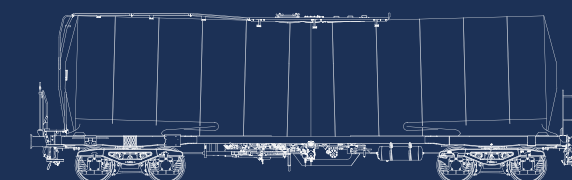
SPECIFICATIONS

Track gauge	1 435 mm
Length over buffers	14 140 mm
Tare weight	22,8 t
Max load weight	67,2 t
Max total weight	90,0 t
Bogie type	Y25 Lsd / Y25 Lsi(f)
Brake system	GP / GP-A
Maximum speed (empty)	120 km/h
Maximum speed (loaded at 22,5 t/axle)	100 km/h
Load volume	72 m ³
Tank code	L4BH
Tanko material	P355NH
Calculation pressure	10 bar
Test pressure	4 bar
Operating pressure	3 bar
Tank calculation temperature	-20 / +190 °C
Vehicle gauge	G1
Meets standards and regulations	TSI, GCU



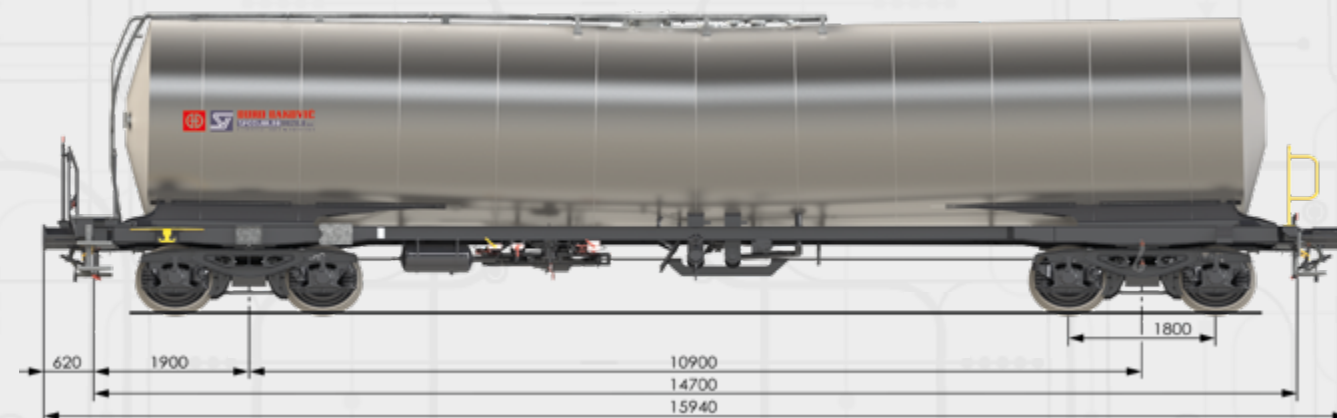
Zacens 72 m³ is a specialized type of cargo wagon designed for transporting temperature-sensitive liquids, such as certain chemicals, oils, and petroleum products. The presence of a heating system makes them particularly suitable for substances that solidify or become highly viscous at lower temperatures.

The main feature of Zacens 72 m³ wagon is a cylindrical tank with a capacity of 72 m³. The tank is constructed from a material with high resistance to chemical corrosion. It is strong enough to withstand internal pressures and the physical demands of transport. The heating capability allows these wagons to transport substances that need to be kept at a certain temperature. As part of its safety features, the wagon includes a reinforced tank, a pressure relief valve and emergency shutoff valves.





Zacens 78 m³

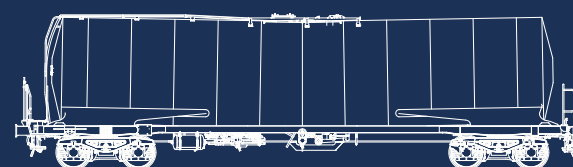


SPECIFICATIONS

Track gauge	1 435 mm
Length over buffers	15 940 mm
Tare weight	24,5 t
Max load weight	65,5 t
Max total weight	90,0 t
Bogie type	Y25 Lsd / Y25 Lsi(Đ)
Brake system	GP / GP-A
Maximum speed (empty)	120 km/h
Maximum speed (loaded at 22,5 t/axle)	100 km/h
Load volume	78 m ³
Tank code	L4BH
Tank material	P355GH
Calculation pressure	10 bar
Test pressure	4 bar
Operating pressure	3 bar
Tank calculation temperature	-20 / +190 °C
Vehicle gauge	G1
Meets standards and regulations	TSI, GCU

Zacens 78 m³ is a specialized type of cargo wagon designed for transporting temperature-sensitive liquids, such as certain chemicals, oils, and petroleum products. The presence of a heating system makes them particularly suitable for substances that solidify or become highly viscous at lower temperatures.

The main feature of Zacens 78 m³ wagon is a cylindrical tank with a capacity of 78 m³. The tank is constructed from a material with high resistance to chemical corrosion. It is strong enough to withstand internal pressures and the physical demands of transport. The heating capability allows these wagons to transport substances that need to be kept at a certain temperature. As part of its safety features, the wagon includes a reinforced tank, a pressure relief valve and emergency shutoff valves.





Zacns 88 m³



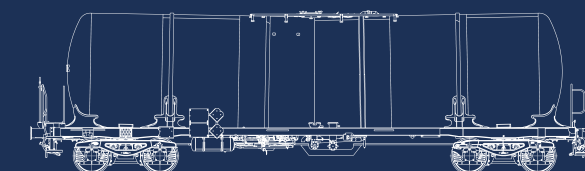
SPECIFICATIONS

Track gauge	1 435 mm
Length over buffers	15 000 mm
Tare weight	21,0 t
Maximum total weight	90,0 t
Bogie type	Y25 Lsd / Y25 Ls(f)
Brake system	GP-A
Max speed (empty)	120 km/h
Max speed (loaded at 22,5 t/axle)	100 km/h
Tank load volume	88 m ³
Max operating pressure	3 bar
Tank material	P355N
Loading hole diameter	500 mm (DN 500)
Discharge pipe diameter	100 mm (DN 100)
Min. curve radius	35 m
Vehicle gauge	G1
Complies with standards and regulations	TSI, EN, GCU



Zacns 88 m³ is a specialized cargo wagon designed for the transportation of liquid goods, including hazardous substances. It is especially effective for carrying light density petroleum products.

The tank is discharged through the lower side, through the discharge pipe DN 100. The wagon design meets the requirements of RID, TSI, EN standards, and has TEN GE marking for traffic operation.





Zacns 98 m³



SPECIFICATIONS

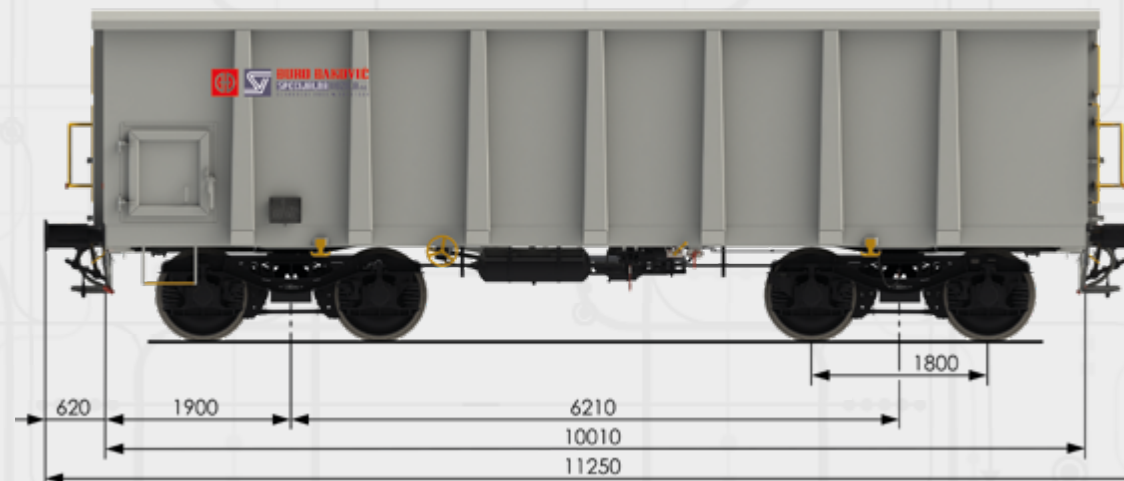
Track gauge	1 435 mm
Length over buffers	15 000 mm
Tare weight	22,5 t
Maximum total weight	90,0 t
Bogie type	Y25 Lsd / Y25 Lsi
Brake system	GP-A
Max speed (empty)	120 km/h
Max speed (loaded at 22,5 t/axle)	100 km/h
Tank volume	98 m ³
Max. operating pressure	3 bar
Tank material	P355N
Loading hole diameter	500 mm (DN 500)
Discharge pipe diameter	100 mm (DN 100)
Min. curve radius	35 m
Vehicle gauge	G1
Complies with standards and regulations	TSI, EN, GCU

Zacns 98 m³ is a specialized cargo wagon designed for the transportation of liquid goods, including hazardous substances, it is especially efficient for light density petroleum products. The tank is discharged through the lower side, through the discharge pipe DN 100. The wagon design meets the requirements of RID, TSI, EN, standards and has TEN GE marking for traffic operation.





Eamnos 60 m³



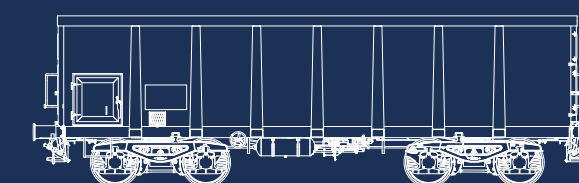
SPECIFICATIONS

Track gauge	1 435 mm
Length over buffers	11 250 mm
Tare weight	19,0 t
Max loading weight	71,0 t
Max total weight	90,0 t
Bogie type	Y25 Lsd / Y25 Lsi(f)
Brake system	GP / GP-A
Max speed (empty)	120 km/h
Max speed (loaded at 22,5 t/axle)	100 km/h
Max loading volume	60 m ³
Vehicle gauge	G1
Complies with standards and regulations	TSI, GCU



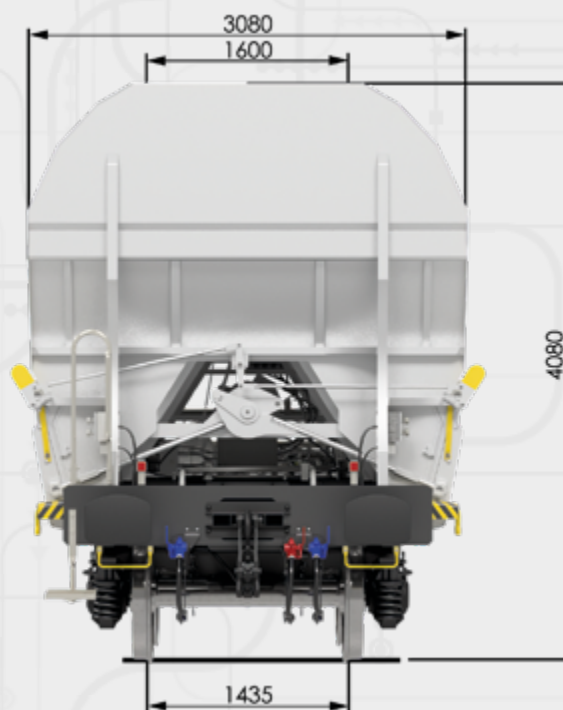
Eamnos 60 m³ cargo wagon is a versatile and robust open-top freight car. It is specifically engineered to transport heavy, loose, and bulk materials. Its high-sided and reinforced construction makes it ideal for industrial applications, such as scrap metal transport, construction debris removal, and for carrying minerals.

The Eamnos 60 m³ features an open-top design, which is ideal for loading and unloading bulk materials by using cranes, grabbers, or other heavy machinery. The relatively high side walls of this wagon provide a large volume for carrying bulk cargo. Its walls and floors are reinforced to prevent damage from the rough cargo that is typically transported. The wagon is engineered to maintain stability even when loaded unevenly, which is crucial when carrying materials that may shift during transit.





Falns 64 m³

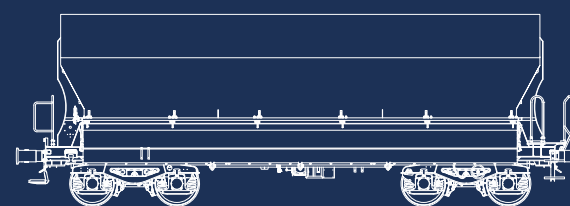


SPECIFICATIONS

Track gauge	1 435 mm
Length over buffers	12 100 mm
Tare weight	20,2 t
Max load weight	69,8 t
Max total weight	90,0 t
Bogie type	Y25 Lsi(f)
Brake system	GP-A
Max speed (empty wagon)	120 km/h
Max speed (loaded at 22,5 t/axle)	100 km/h
Wagon case volume	64 m ³
Load opening length	10 080 mm
Load opening width	1 600 mm
Unload opening length	9 180 mm
Unload opening width	≈ 500 mm
Vehicle gauge	G1
Complies with standards and regulations	TSI, EN, GCU

Falns 64 m³ hopper cargo wagon is specifically designed for the efficient transport of limestone and different types of bulk goods which are resistant to weather conditions. Its moderate loading volume and durable construction, combined with large loading opening and one door on each side, providing easy loading/unloading with excellent sealing, makes it perfect for various types of bulk cargo.

Open-top design allows for easy loading of bulk materials from above. Sloped wagon floor design enables efficient unloading of cargo by gravity, through hatches located on the sides of wagon. The hatches are equipped with a main and auxiliary pneumatic system which ensures operating safety. Locking device operation is also done by pneumatic system that provides locking/unlocking of doors on both lateral sides of the wagon at the same time.





Talns 64 m³



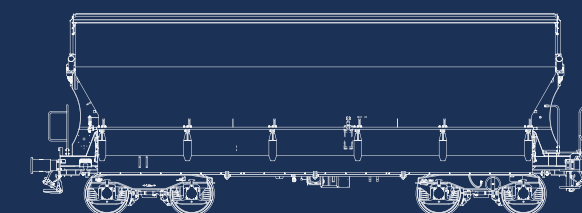
SPECIFICATIONS

Track gauge	1 435 mm
Length over buffers	12 100 mm
Tare weight	21,0 t
Max total weight	90,0 t
Bogie type	Y 25 Lsi(f)
Brake system	GP-A
Max speed (empty)	120 km/h
Max speed (loaded at 22,5 t/axle)	100 km/h
Max loading volume	64 m ³
Loading opening width	1 200 mm
Unloading opening length	9 180 mm
Vehicle gauge:	G1
Complies with standards and regulations	TSI, EN, GCU



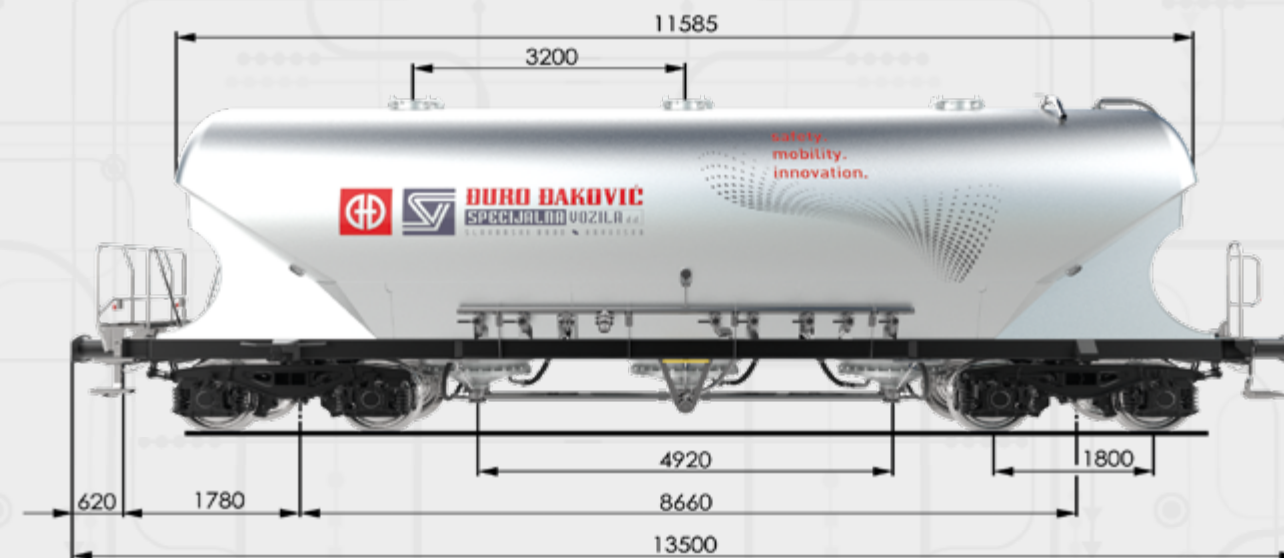
Talns 64 m³ is a specialized freight wagon designed for the efficient transportation of bulk materials sensitive to weather conditions, and it is optimized for the transportation of limestone. The wagon has a loading opening at the top that is covered with a moveable roof, and one door at each side for discharging.

The cargo is loaded at the top of the wagon. Discharge is done by gravity through wagon side doors, and material flows outside of the rail tracks. The roof and the two unloading doors (one on each side) are operated by a pneumatic system. Locking device operation is also done by pneumatic system that provides locking/unlocking of doors on both lateral sides of the wagon at the same time.





Uacns 75 m³

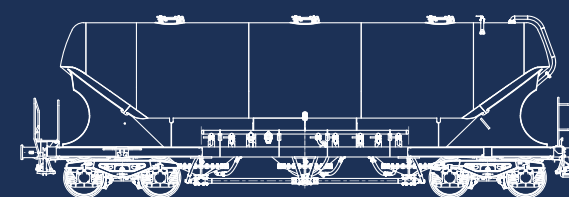


SPECIFICATIONS

Track gauge	1 435 mm
Length over buffers	13 500 mm
Tare weight	21,0 t
Bogie type	Y25 Lsi
Brake system	GP-A
Maximum speed (empty)	120 km/h
Maximum speed (loaded at 22,5 t/axle)	100 km/h
Load volume	75 m ³
Working pressure	2,50 bar
Test pressure	3,75 bar
Wall thickness vessel	5 mm
Wall thickness dished ends	6 mm
Manholes	3 manholes (DN 500)
Hopper	1 hopper with 3 cones DN 1000
Discharge line connection port	DN 100/125/150 coupling
Air supply connection port	DN 80/100 coupling
Vent line valve	DN 50 on both sides
Vehicle gauge	G1
Meets standards and regulations	TSI, EN, GCU

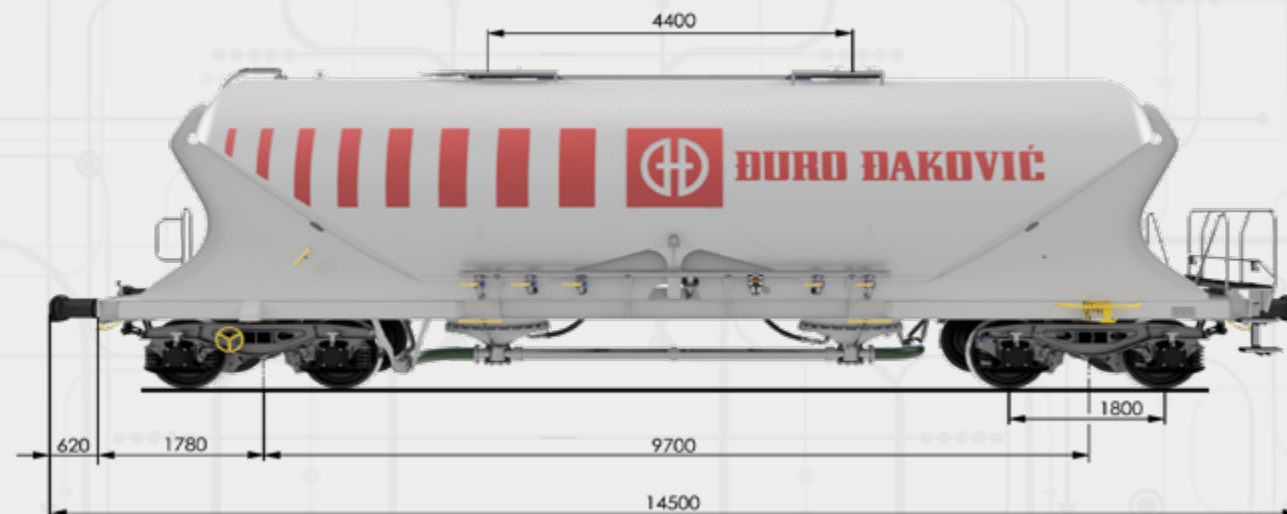
Uacns 75 m³ is a specialized freight wagon used for the transport of powdered cargo sensitive to weather conditions, such as cement, limestone, aluminum sulphate chalk, etc.

The tank, consisting of 3 discharge cones, can hold up to 75 m³ of powdered cargo. The wagon is loaded through three manlid openings (DN 500) located at the top of the wagon. The wagon is discharged under pressure of up to 2,5 bar. An optimized pneumatic pressure system guarantees the shortest time of discharge and minimum retaining cargo quantity after discharging, which lowers downtimes and operational costs.



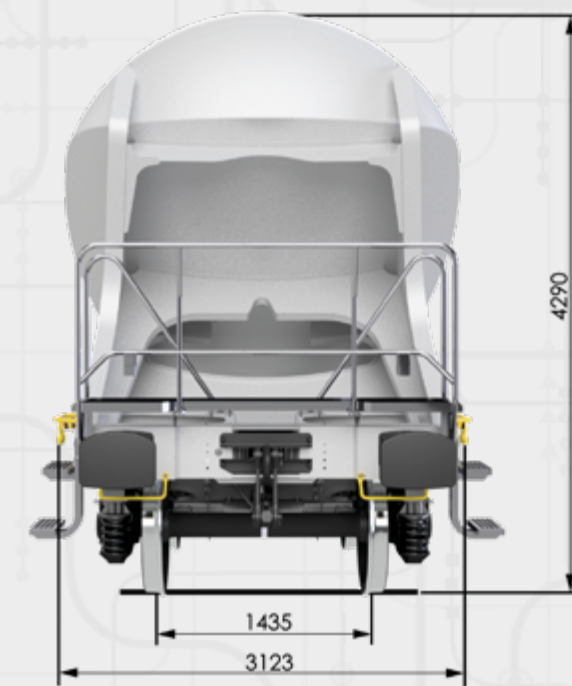


Uacns 68 m³



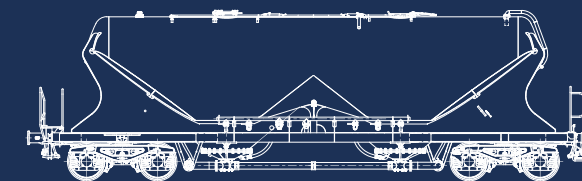
SPECIFICATIONS

Track gauge	1 435 mm
Length over buffers	14 500 mm
Tare weight	20,0 t
Bogie type	Y25 Lsi / Y25 Lsif
Brake system	GP-A
Max speed (empty)	120 km/h
Max speed (loaded at 22,5 t/axle)	100 km/h
Max load volume	68 m ³
Working pressure	2,50 bar
Test pressure	3,75 bar
Wall thickness vessel	5 mm
Wall thickness dished ends	6 mm
Number and type of manholes	2 (DN 500)
Hopper	1 hopper, 2 cones (DN 1000)
Discharge line connection port	DN100/125/150 coupling
Air supply connection port	DN 80/100 coupling
Vent line valve	DN 50 on both sides
Vehicle gauge	G1
Complies with standards and regulations	TSI, GCU



Uacns 68 m³ is a specialized freight wagon used for the transport of powdered cargo sensitive to weather conditions and it is optimized for transportation of cement.

The tank, consisting of 2 discharge cones, can hold up to 68 m³ of powdered cargo. The wagon is loaded through two manlid openings (DN 500) located at the top of the wagon. The wagon is discharged under pressure of up to 2,5 bar. An optimized pneumatic pressure system guarantees the shortest time of discharge and minimum retaining cargo quantity after discharging, which lowers downtimes and operational costs.



We build  wagons for the
GREENER FUTURE



ĐURO ĐAKOVIĆ

MEMBER OF



PROMET
GROUP

  ĐURO ĐAKOVIĆ

