

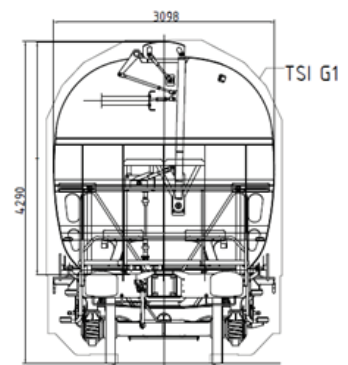

ĐURO ĐAKOVIĆ
SPECIJALNA VOZILA d.d.
SLAVONSKI BROD • HRVATSKA

Tagnpps

95 m³

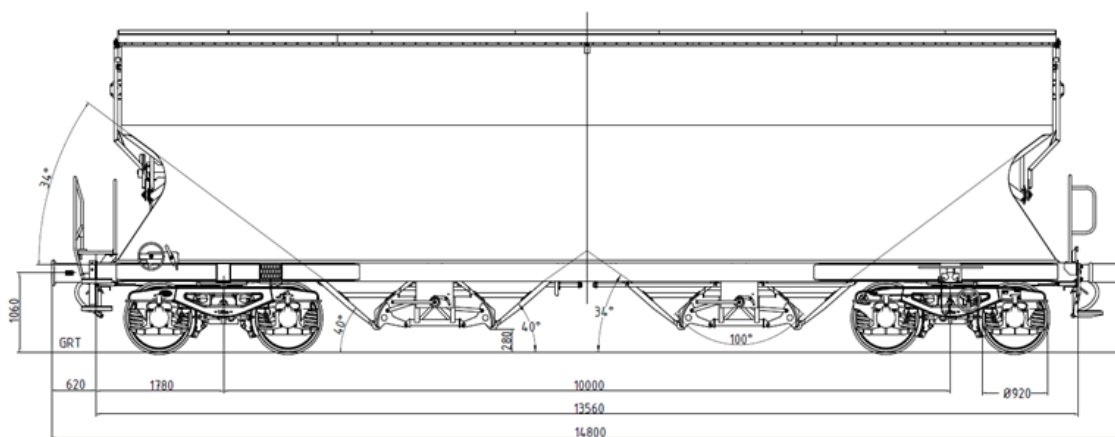

We build wagons
for the greener future.

Tagnpps 95 m³



TECHNICAL DATA:

Track gauge:	1435 mm
Tare weight:	19,7 t ± 3 %
Axle load:	22,5 t
Loading volume:	95 m ³
Speed loaded wagon:	100 km/h
Speed empty wagon:	120 km/h
Unloading opening:	2x(2x350x1000) mm
Loading opening:	12730x800 mm
Bogie type:	Y25 Lsi/Y25 Lsif
Brake system:	GP-A (K), 1x Bgu
Handbrake:	20%, ground operated
Draw gear:	1500kN
Buffers:	A class – 40kJ
Preparation for automatic coupler:	UIC 530-1, 6a

This self-discharging covered hopper is suitable for transport of bulk loads-grain, corn, soya, etc., which need to be protected against weather conditions.

Loading of the wagon is from the top. Roof is manually operated from the ground. Unloading of the wagon is from the bottom through two pairs of sliders, manually operated from both wagon sides – each pair separately.

Painting and incriptions

Outer coating according to valid regulations and requests of ordering party. In compliance with GCU regulations

2-K Epoxy + 2-K Polyurethane